

Introduction

To ensure that the Intermec PartnerNet community has in-depth sales and technical knowledge of our product features, applications and benefits, all Platinum and Gold Partners are required to complete and maintain certain sales authorizations and technical certifications. It is essential that Platinum and Gold Partners are knowledgeable in configuring and installing Intermec products, as well as providing post-sales technical support to their end-user customers. To that end Intermec has developed two new partner career designations that will be issued beginning in February 2010. The sales designation is Intermec Sales Consultant (ISC) and the technical designation is Intermec Certified Engineer (ICE).

These requirements apply to Solutions Providers and Printer and Media Partners. Compliance by Independent Software Vendors is optional.

The following outlines the requirements for each partner level.

Platinum Partner Training Requirements

Platinum Partners are required to have at least four Intermec Sales Consultants and at least two Intermec Certified Engineers on staff. These requirements vary by geographic region and are defined by the table below in the section labeled "Timeline for Compliance". The individuals applying for the Intermec Sales Consultant designation must complete one category of Basic Technology and Products web-based training for the sales track. The individuals applying for the Intermec Certified Engineer designation must complete all required Technical Introduction and Basic Modules web-based training followed by the associated instructor-led classes as defined by the technical training roadmap on page four.

To meet the ISC and ICE requirements partners must complete the course and/or pass an assessment test with a score of 80 percent or greater, in one of four technical specialization categories as listed below. See page three for additional course/class details.

- **In-Premise**
- **In-Field**
- **Printer**
- **RFID**

Because ISC and ICE are granted to an individual, the same person must complete all requirements. Certifications will be valid for two years; renewal is required to maintain the designation.

Note: *Technical courses beyond the scope of certification will be made available but are not mandatory.*

Gold Partner Training Requirements

Gold Partners are required to have at least two Intermec Sales Consultants and at least one Intermec Certified Engineer on staff. These requirements vary by geographic region and are defined by the table below in the section labeled "Timeline for Compliance". The Intermec Sales Consultant must complete one category of Basic Technology and Products web-based training for the sales track. The Intermec Certified Engineer must complete all required Technical Introduction, Basic Modules web-based training and the associated instructor-led classes as defined by the technical training roadmap. The designations will be awarded to the individuals who successfully complete all required courses/classes and who pass the assessment test with a score of at least 80 percent. The designations are valid for two years and renewal is required to maintain them.

Note: *Technical courses beyond the scope of certification will be made but are not mandatory.*

There is no requirement for Silver Partners to be certified/**Sales and Technical Test-out Option**

All partner employees are permitted to test-out of any of the required Basic Technology and Product web-based training courses with a passing score of 80 percent.

All partner employees are permitted to test-out of any of the required technical training courses with a passing score of 80 percent through the Intermec Advanced Level Exam Program (IALEP). If the individual scores below 80 percent, they are required to attend the current certification specialization course.

Timeline for Compliance

Partners must be in compliance with training requirements by December 31 of each year to sustain their PartnerNet Program partnership level for the following year.

Requirements by Partner Type	United States		Canada	
	Intermec Sales Consultant	Intermec Certified Engineer	Intermec Sales Consultant	Intermec Certified Engineer
Platinum	4 by 12/31/10	2 by 12/31/10	2 by 12/31/10	1 by 12/31/10
Gold	2 by 12/31/10	1 by 12/31/10	1 by 12/31/10	1 by 12/31/10

Partners brought into the program at the Platinum or Gold level will have until 12/31/2010 or 90 days, whichever is greater from their acceptance date to complete the ICE requirement.

Evaluation

Intermec will perform an annual audit to confirm that all PartnerNet Members met the sales and technical training requirements outlined in this document.

If a Partner is not in compliance, a one-time grace period of 90 days will be granted to allow the Partner organization to reach minimum training levels. If the Partner does not meet the timeline, the Partner level may be adjusted down and the partner may forfeit benefits.

Note: ISC and ICE designations are granted to the individual, not the company and are valid if the individual is employed by another PartnerNet company. These certifications can be obtained only while employed by an Intermec PartnerNet Member.

Registration

To register for Intermec University and gain access to online technical training modules, go to www.intermecuniversity.com.

Contacts

For questions about Intermec's technical training requirements, please contact your Channel Business Manager or Intermec Authorized Distributor.

For questions about Intermec University or to enroll, please send an email to: intermecuniversity@intermec.com

Training Roadmaps

NA Intermec Sales Consultant (ISC) Training Road Map

Advanced Level Exam (test out) = Certification

In-Field Certification
In-Premise Certification
Printers Certification
RFID Certification

Basic Technology and Products (BT&P)	Product Introduction (PI)	(BT&P) Assessment
WBT	WBT	In Field In Premise Printers RFID
		WBT

Note:

WBT – Web-based Training

NA Intermec Certified Engineer (ICE) Training Road Map

Advanced Level Exam (test-out) = Certification

OR

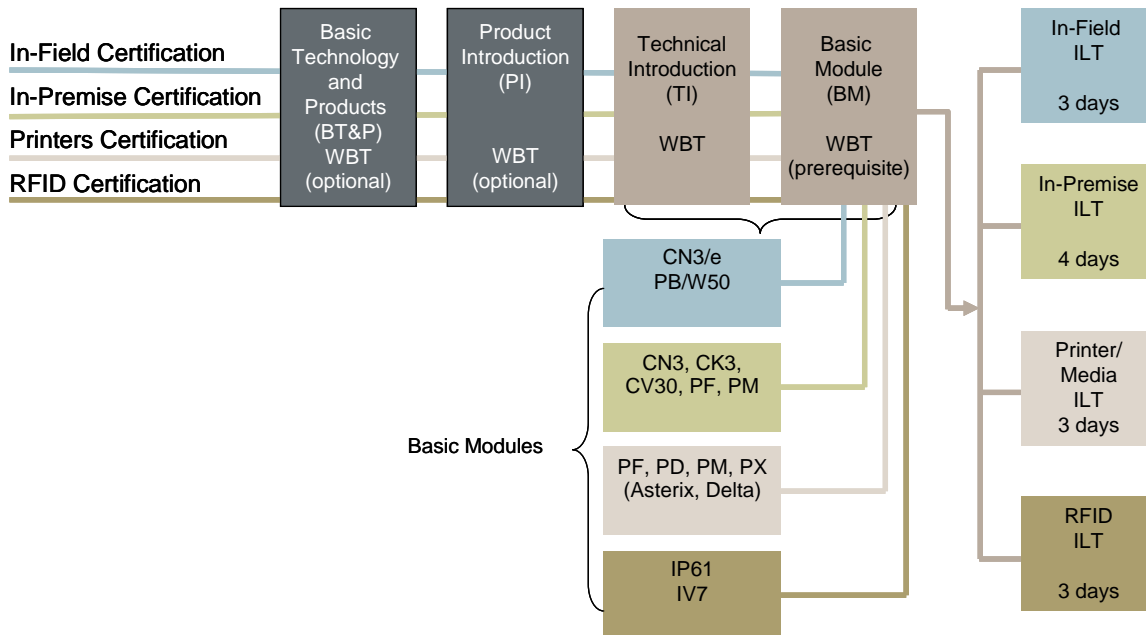

Notes:

WBT – Web-based training

ILT – Instructor-led training

The Technical Introduction (TI) modules are available on Intermec University to anyone who has an Intermec University account. Completion of the specified Basic Modules (BM) is required prior to attending the ILT workshop. The Basic Modules are only available to partners who have signed up for the ICE technical certification.

The PartnerNet Program policies may from time-to-time be amended at Intermec's sole discretion and Intermec will attempt to provide Program Members with at least (30) days advance notification of any material changes.